

SKZ1052D Differential Scanning Calorimeter



DSC is designed to determine the inner heat transition relating to temperature and heat flow, it is widely used in the field of polymer development, performance testing & quality control. DSC research and development includes the following field: glass transition temperature, melting point, cold crystallization, crystallization, phase transition, oxidation induction time (OIT).

Standards:

ISO/TR10837:1991, ASTM D3895-1998, ASTM E 967, ASTM E 968, ASTM E 793, ASTM D 3895, ASTM D 3417, ASTM D 3418, ISO 11357-6

Main Features:

1. The industrial-grade 7-inch touch screen displays rich information.
2. Brand-new metal furnace body structure, with better baseline and higher accuracy.
The heating adopts indirect conduction method, which has high uniformity and stability, reduces pulse radiation, and is better than traditional heating mode.
3. USB communication interface, strong versatility, reliable and uninterrupted communication, supports self-recovery connection function.
4. Automatically switch the two-channel atmosphere flow, fast switching speed and short stabilization time. At the same time, a protective gas input is added.
5. The software is simple and easy to operate.

Technical parameters:

Temperature range	-35℃~550℃
Heating rate	0.1~80℃/min
Cooling rate	1~20℃/min
Temperature resolution	0.001℃
Temperature fluctuations	±0.001℃

SKZ Industrial Co., Limited

D-11, No.9 Lanxiang road, Tianqiao District, Jinan, Shandong province, China.

Tel: +86-531-68825087, 0086-15692312640

Web: www.skzindustrial.com



Temperature repeatability	$\pm 0.1^{\circ}\text{C}$
Constant temperature time	Program setting $\leq 24\text{h}$
DSC range	0~ $\pm 60\text{mW}$
DSC noise	0.01 μW
DSC resolution	0.01 μW
DSC accuracy	0.01mW
Atmosphere control gas	Nitrogen, Oxygen (instrument switch automatically)
Gas flow rate	0-300mL/min
Gas pressure	0.2MPa
Control Mode	Rising temperature, constant temperature(full automatic)
Curve scanning	Rising scan, cooling scan
Gas flow control	Built-in digital flow meter & Software control, automatic
Display	24 bit 7 inches LCD touch screen display
Data interface	standard USB connector
Parameter standard	With standard material, with calibration function, the user may correct temperature and heat enthalpy
Software	4 in 1 operating software, can switch to DSC, DTA, TGA, STA
Thermocouples	Total 3 sets of thermocouples for: 1). Test sample temperature 2). test furnace temperature, 3). Test internal ambient temperature
Cooling device	Liquid nitrogen refrigeration
Power	AC220V/50Hz

Packing List

Host instrument	1PC
CD	1PC
Data Line	1PC
Power Line	1PC
Aluminum crucibles	100PCS
Ceramic crucibles	100PCS
pure tin grains	1bag
Fuse 4A	5PCS

SKZ Industrial Co., Limited

D-11, No.9 Lanxiang road, Tianqiao District, Jinan, Shandong province, China.

Tel: +86-531-68825087, 0086-15692312640

Web: www.skzindustrial.com

Furnace structure:

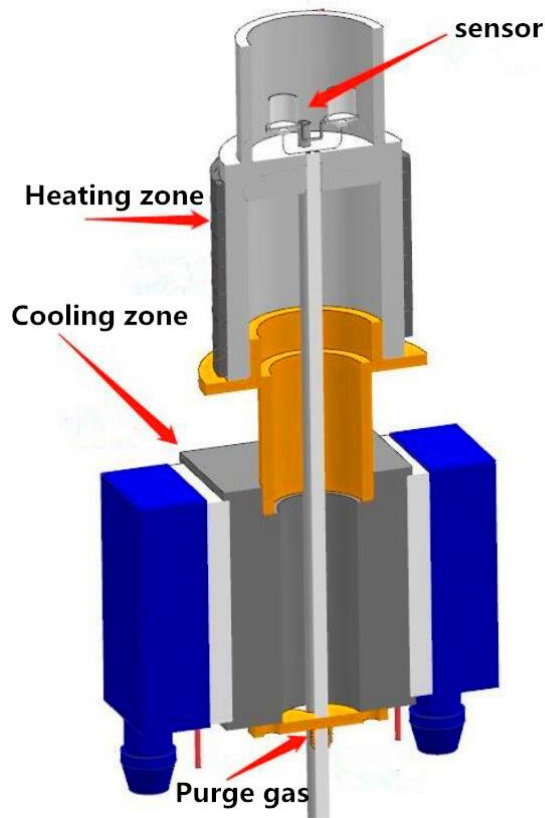

Test Curves:

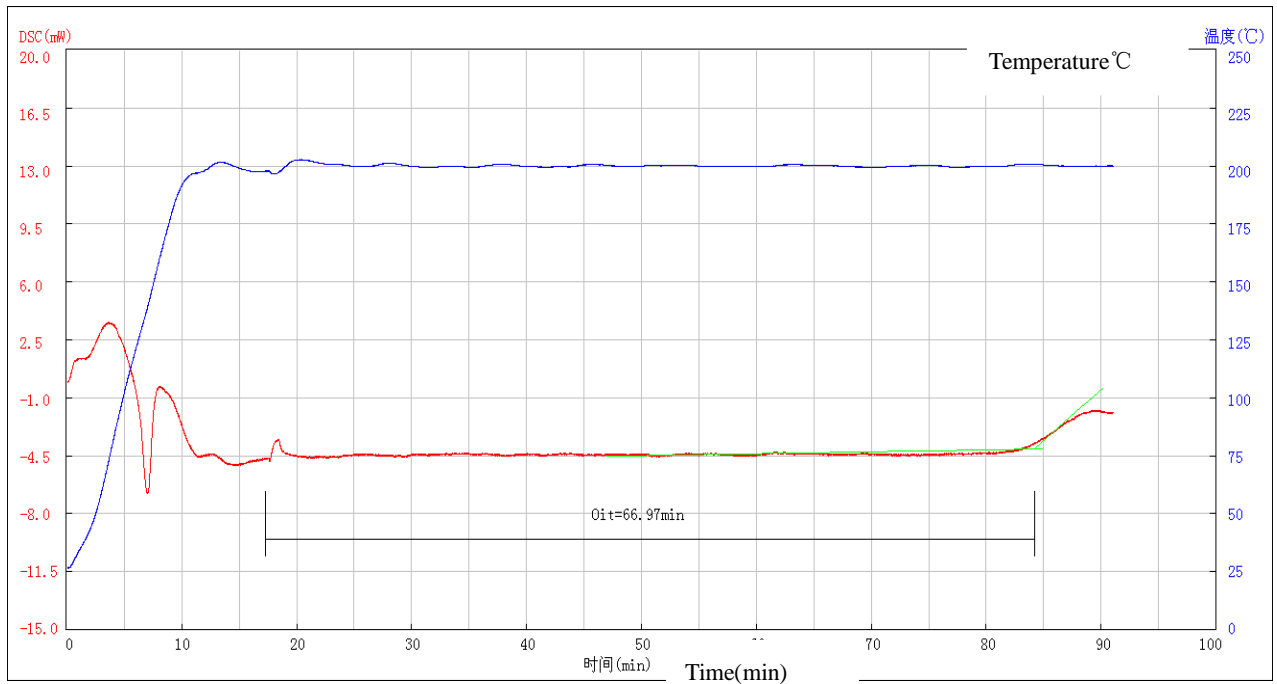

SKZ Industrial Co., Limited

D-11, No.9 Lanxiang road, Tianqiao District, Jinan, Shandong province, China.

Tel: +86-531-68825087, 0086-15692312640

Web: www.skzindustrial.com

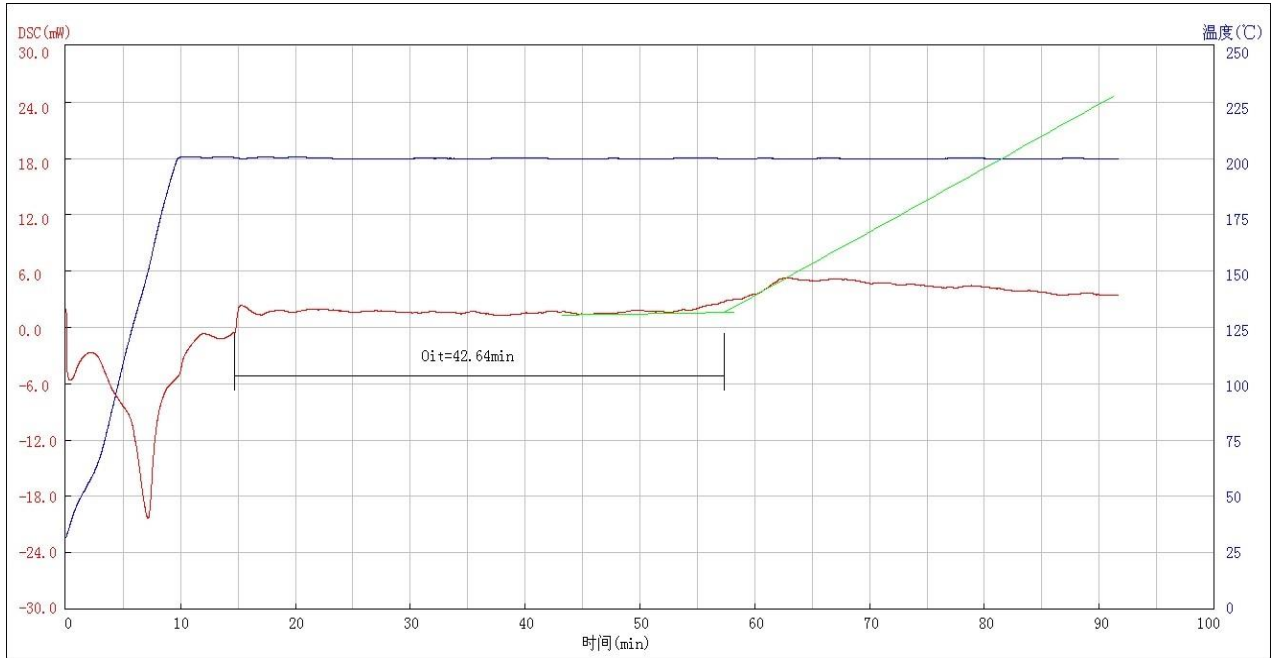

SKZ Industrial Co., Limited

D-11, No.9 Lanxiang road, Tianqiao District, Jinan, Shandong province, China.

Tel: +86-531-68825087, 0086-15692312640

Web: www.skzindustrial.com